

With this system hot water is heated and circulated through pipes and radiators located throughout the house. The water gives up its heat at the radiators and the cooler water flows back to the boiler to be reheated and re-circulated. All hot water systems must have an expansion tank to temporarily store increased water volume. Over time an air-cushion tank can become **waterlogged**. Some newer systems are equipped with a rubberized diaphragm that separates the air cushion from the water. A leaky diaphragm can also create a waterlogged tank.

A **GRAVITY SYSTEM** is inefficient and slow to respond to changing demands for heat. It works on the principle of convection - hot water rises and cooler water descends. To minimize flow resistance, the pipe size is about **three inches** compared to one inch pipes for a forced system. The system may be classified as open or closed. In an **open system**, the expansion tank has an overflow pipe open to the atmosphere. The tank must be located above the highest radiator in the house. Since excessive pressure will discharge through the overflow pipe, the boiler does not require a **pressure-relief valve**.

In a **CLOSED SYSTEM**, no portion of the expansion tank is open to the atmosphere. Hence it can be located anywhere in the system. It operates at higher temperatures and thus permits the use of smaller radiators. Boilers were typically made with heavier gauge steel and may last about 50 years – some as old as 80 years! The automatic **pressure-reducing valve** reduces household water supply from 30 to 60 psi (pounds per square inch) to **12 to 25 psi**. The boiler is also equipped with a **pressure-relief valve** that discharges if the pressure exceeds 30 psi.

A **PRESSURE (OR PUMPED) SYSTEM** is similar to a closed gravity system but it uses a centrifugal pump to circulate the water through the system. This system uses a smaller boiler than a gravity system and is identifiable by the presence of the circulating pump in the distribution return pipe just before the boiler. Boilers are made of either cast iron or steel and may last up to 30 years. Some newer systems have a **condensing** (high-efficiency) boiler that achieves an efficiency of about **85%** compared to **60%** for a **conventional** boiler. The cooled gases are vented through plastic pipe through a side wall. These boilers require an induced draft fan (power vent) and an outside air-intake for combustion. Another type of high efficiency unit is a **gas-fired Hydro-pulse boiler** which achieves an efficiency of **90%**. The heat is generated as a result of 60 to 70 bursts of gas-air mixture per second. Since this system is noisy, vibration isolators are installed between the boiler and distribution pipes.

A **SERIES LOOP** is the simplest pipe distribution system. Typically on smaller homes, the radiators are connected with one pipe that serves both as the supply and return with no temperature control per room. A **one pipe** is similar to a series loop but the radiators have two risers - one at each end. The inlet riser has a shutoff valve. This permits room-by-room heat control but there is still considerable temperature difference between the first and last radiator in the system. To compensate, larger radiators are used downstream in the system to emit heat comparable to smaller ones closer to the boiler. The most costly distribution system is a **two-pipe**. There is a pipe for supply and another for the return. As a result, the temperature difference between the hot water entering the first and last radiator is small and usually used in homes with **zone heating**. A thermostat controls the heat for each zone.

Boilers that provide domestic hot water operate all year round. The thermostat does not control the burner; it controls only the circulating pump. The burner is activated by an **aquastat or limit control thermostat** that controls the boiler water temperature. Zone valves prevent the hot water rising through the system. If there are no zone valves then a **flow-control** valve is required on the supply main.

MAINTENANCE ITEMS FOR SERVICE TECHNICIAN:

- **BLEED THE AIR FROM RADIATORS OR CONVECTORS TO IMPROVE EFFICIENCY AND REDUCE HAMMERING**
- **CHECK THE PRESSURE GAUGE (THE MOVING POINTER INDICATES THE CURRENT WATER LEVEL)**
- **DRAIN THE EXPANSION TANK ON A REGULAR BASIS (OR RECHARGE DIAPHRAGM TANK)**
- **CHECK THE RELIEF VALVE ONCE A MONTH**

For further information contact your local public utilities office, a licensed HVAC contractor or the American Society of Heating, Refrigerating and Air-conditioning Engineers (ASHRAE) or the Heating, Refrigerating and Air conditioning Institute of Canada (HRAI).

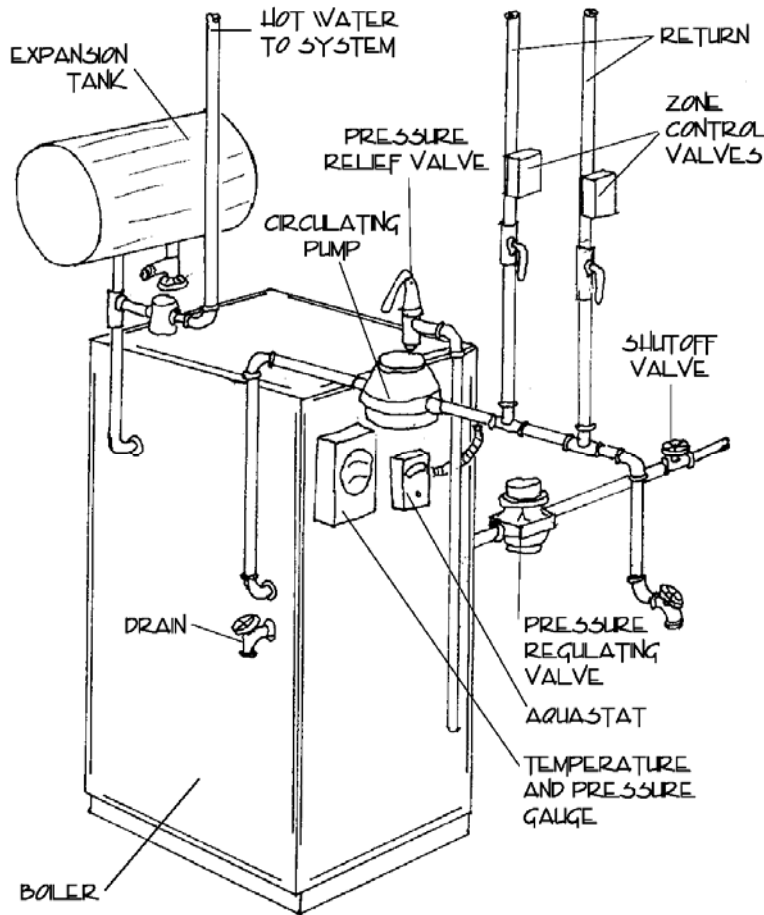

TYPICAL HOT-WATER BOILER

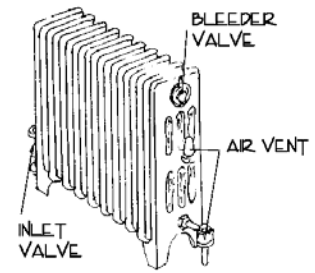
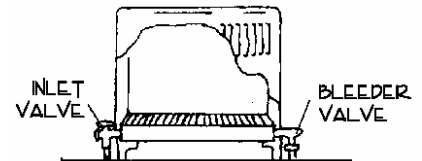
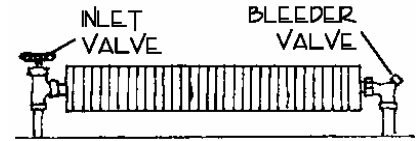

DETAILS OF A HOT-WATER CONVECTOR AND RADIATOR

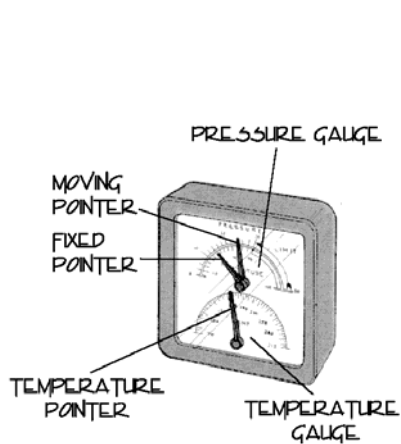

PRESSURE AND TEMPERATURE GAUGE

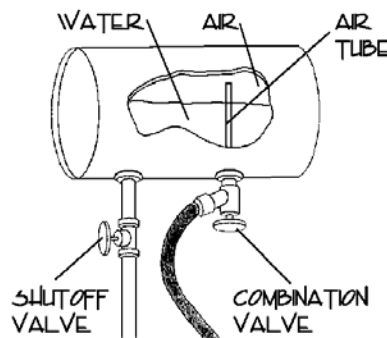

SEALED AND A DIAPHRAGM EXPANSION TANK

