

In a forced warm-air system, a blower fan pulls air from various rooms through the house into the cold-air return duct. The air passes through a filter, into the furnace and is heated. The warm-air is then forced into the rooms through ducts and registers that are located adjacent to exterior walls near windows or doors.

FORCED-AIR MAINTENANCE COMPONENTS FOR SERVICE TECHNICIAN:

- CLEAN OR REPLACE THE AIR FILTER MONTHLY DURING THE HEATING SEASON
- CLEAN THE FAN BLOWER BLADES AT THE START OF EACH SEASON (ESPECIALLY IS THERE IS A DRYER NEARBY)
- CHECK THE BELT FOR WEAR, ALIGNMENT AND TENSION - THE BELT SHOULD HAVE ½" TO ¾" DEFLECTION
- EXAMINE THE DUCTS FOR LEAKS AND SEAL WITH DUCT TAPE
- KEEP COLD-AIR RETURNS CLEAR OF FURNITURE (IT IS INEFFICIENT AND MAY LEAD TO BACKDRAFTING)
- LOOK FOR SIGNS OF SOOT AROUND WARM-AIR REGISTERS – THIS MAY INDICATE A CRACKED HEAT EXCHANGER
- CHECK AUXILIARY COMPONENTS (HUMIDIFIER AND CENTRAL AIR CONDITIONER) FOR LEAKS INTO THE UNIT

Gas burners are usually associated with warm-air furnaces but could also fuel hot water or steam heating systems. When the thermostat calls for heat, the gas valve opens, allowing gas to flow into a manifold and then into venturi tubes where it mixes with air. The mixture is ignited by an electric-spark (intermittent pilot) or a constant pilot light. The heat exchanger separates the circulated warm air and exhaust gases. *The heat exchangers should be checked for cracks every few years.* The thermocouple closes the gas valve if the pilot is not working. It is a heat-sensing probe that holds the gas valve open when it is hot.

CONVENTIONAL, or **natural aspirating**, furnace has a **60 to 70%** efficiency. The unit has a large air requirement in order for exhaust gases to vent up through a chimney. In most jurisdictions, a conversion from oil to gas requires a metal liner in the chimney to ensure proper draft to reduce condensation.

MID-EFFICIENCY, is similar to a conventional furnace but achieves a **75 to 85%** efficiency. It does so by incorporating an **induced draft fan**. Some units also have a **motorized damper**, that closes when the unit is off so that heated air is not lost up the chimney. In some areas, units with plastic flues (about five inches in diameter) from the furnace to the chimney are not permitted and must be replaced. *Check your local utilities office for regulations concerning plastic vent pipes for mid-efficiency furnaces in your area.*

HIGH-EFFICIENCY, or **condensing furnace**, achieves a **90 to 97%** efficiency. Increased efficiency is due to a secondary heat exchanger that extracts heat from the exhaust gases that will normally flow up the chimney. Instead of a flue, the unit incorporates an **induced draft fan** or **power vent fan** and plastic piping to vent the cooled gases through a side wall. Condensate drainage piping carries the condensate from the cooled gases to a waste pipe. In some units, a pump discharges the condensate to the exterior. Units with a sealed combustion system also have an intake air duct so that outside air is used for combustion. A **pulse-combustion** produces about 60 to 70 tiny explosions of air-gas mixture per second in the combustion chamber instead of a continuous flow of fuel as with most common high-efficiency units. Since this system is noisy, a vibration isolator (canvas fabric) is installed between the furnace and plenum.

GAS BURNER MAINTENANCE ITEMS FOR SERVICE TECHNICIAN:

- **BURNERS DO NOT LIGHT** – CHECK TO SEE IF THERE IS A PILOT FLAME; CHECK THE THERMOCOUPLE POSITION AND CONNECTION; CHECK THE BREAKER OR FUSE WITH AN ELECTRIC-SPARK IGNITION
- **PILOT FLAME WILL NOT STAY ON** – CHECK THAT THE HEAD OF THE THERMOCOUPLE IS DIRECTLY IN THE FLAME; REPLACE THE FAULTY ELECTRIC STARTER; REPLACE THE THERMOCOUPLE
- **INSUFFICIENT HEAT** – ADJUST THE AIR INTAKE; CLEAN CLOGGED BURNER PORTS
- **EXPLODING SOUND AT START-UP** – CLEAN THE PILOT ORIFICE; CLEAN CLOGGED BURNER PORTS OR CROSSOVER
- **BURNER IS YELLOW OR ORANGE** – ADJUST AIR INTAKE; CLEAN MANIFOLD GAS JETS; CLEAN BURNERS

For further information contact your local public utilities office, gas company, a licensed HVAC contractor or the American Society of Heating, Refrigerating and Air-conditioning Engineers (ASHRAE) or the Heating, Refrigerating and Air conditioning Institute of Canada (HRAI).

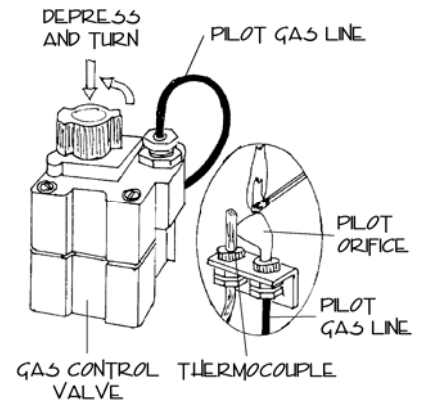
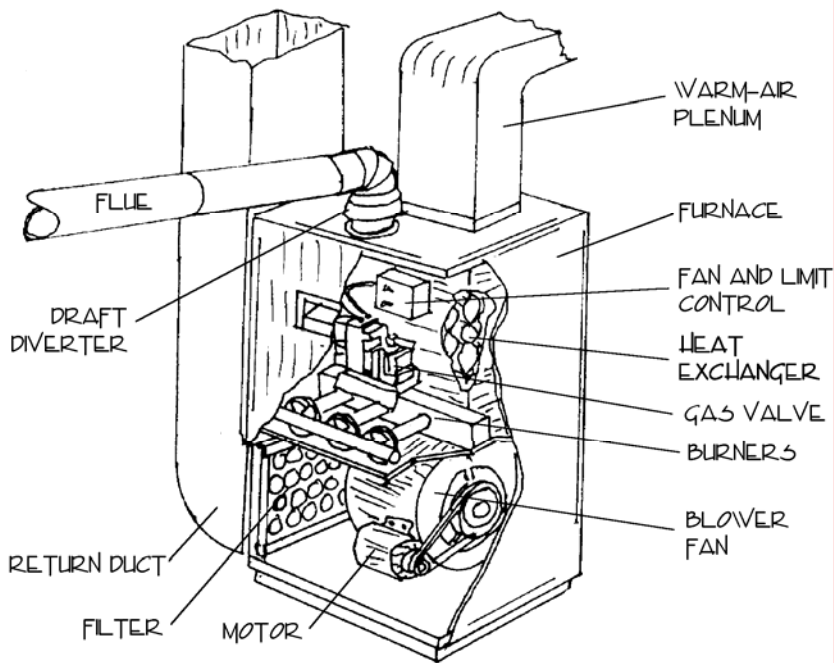

RE-LIGHTING THE PILOT

TYPICAL CONVENTIONAL FURNACE

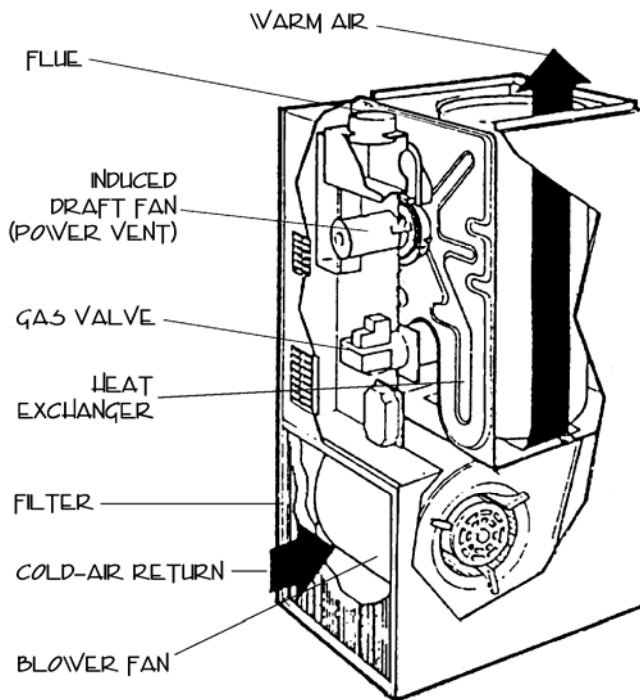

TYPICAL MID-EFFICIENCY FURNACE

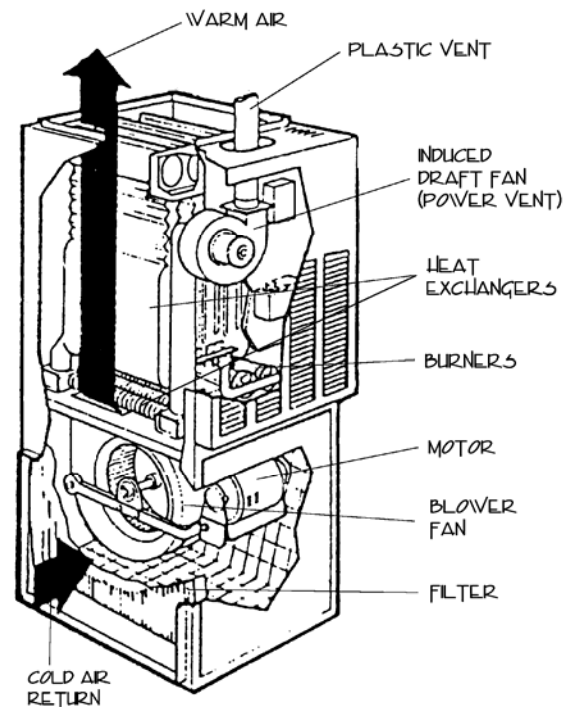

TYPICAL HIGH-EFFICIENCY FURNACE